

## Right Angle Drills

### 300DRA(X)M & 300DRAE(X)M Series

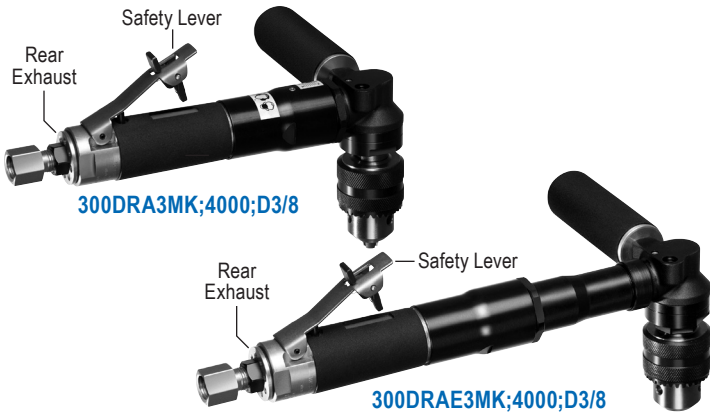

### 400DRA(X)M & 400DRAE(X)M Series

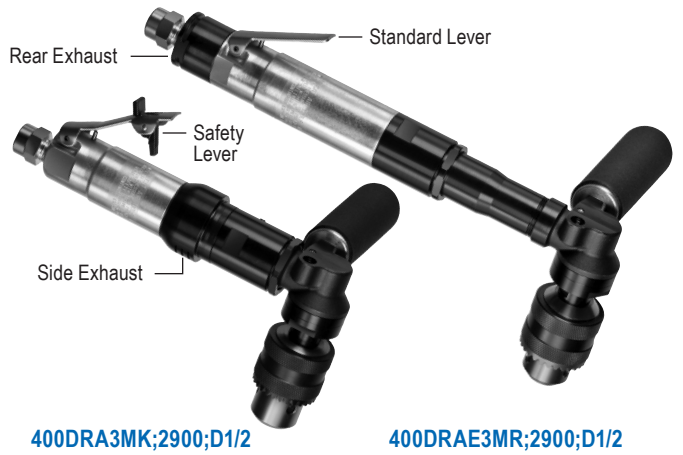

Output	Gear Ratio/Rated Speed	Lever Style	300DRA(X)M MODEL NUMBER	300DRAE(X)M MODEL NUMBER	400DRA(X)M MODEL NUMBER	400DRAE(X)M MODEL NUMBER
300 Series 3/8" (10 mm) Drill Chuck	3:1 300 Series: 4000 RPM 400 Series: 2900 RPM	Standard Lever	300DRA3M;4000;D3/8	300DRAE3M;4000;D3/8	400DRA3M;2900;D1/2	400DRAE3M;2900;D1/2
		Safety Lever	300DRA3MK;4000;D3/8	300DRAE3MK;4000;D3/8	400DRA3MK;2900;D1/2	400DRAE3MK;2900;D1/2
	5:1 300 Series: 3000 RPM 400 Series: 2200 RPM	Standard Lever	300DRA5M;3000;D3/8	300DRAE5M;3000;D3/8	400DRA5M;2200;D1/2	400DRAE5M;2200;D1/2
		Safety Lever	300DRA5MK;3000;D3/8	300DRAE5MK;3000;D3/8	400DRA5MK;2200;D1/2	400DRAE5MK;2200;D1/2
400 Series 1/2" (13 mm) Drill Chuck	8:1 300 Series: 1800 RPM 400 Series: 1300 RPM	Standard Lever	300DRA8M;1800;D3/8	300DRAE8M;1800;D3/8	400DRA8M;1300;D1/2	400DRAE8M;1300;D1/2
		Safety Lever	300DRA8MK;1800;D3/8	300DRAE8MK;1800;D3/8	400DRA8MK;1300;D1/2	400DRAE8MK;1300;D1/2
	21:1 300 Series: 660 RPM 400 Series: 440 RPM	Standard Lever	300DRA21M;660;D3/8	300DRAE21M;660;D3/8	400DRA21M;440;D1/2	400DRAE21M;440;D1/2
		Safety Lever	300DRA21MK;660;D3/8	300DRAE21MK;660;D3/8	400DRA21MK;440;D1/2	400DRAE21MK;440;D1/2
36:1 300 Series: 390 RPM 400 Series: 260 RPM	Standard Lever	300DRA36M;390;D3/8	300DRAE36M;390;D3/8	400DRA36M;260;D1/2	400DRAE36M;260;D1/2	
	Safety Lever	300DRA36MK;390;D3/8	300DRAE36MK;390;D3/8	400DRA36MK;260;D1/2	400DRAE36MK;260;D1/2	

**300DRA3M**

3/5/8: 9.1 Inch (231 mm)  
21/36: 9.6 Inch (244 mm)

1.44 Inch (37 mm)

4.5 Inch (114 mm)

**300DRAE3M**

3/5/8: 12.1 Inch (307 mm)  
21/36: 12.6 Inch (320 mm)

1.44 Inch (37 mm)

4.5 Inch (114 mm)

**HP** 0.7 H.P. (600 kW)

**cfm** 25 cfm (11.8 L/s) Max

**Lbs** 3/5/8: 3.7 Lbs. (1.7 Kg): Short  
21/36: 3.9 Lbs (1.8 Kg): Short  
3/5/8: 4.3 Lbs. (1.9 Kg): Extended  
21/36: 4.5 Lbs (2.0 Kg): Extended

**SUPPLY** 1/4" NPT Inlet  
3/8" (10 mm) Hose Size

**400DRA3M**

3/5/8: 8.9 Inch (226 mm)  
21/36: 9.4 Inch (239 mm)

1.6 Inch (41 mm)

5.3 Inch (135 mm)

**400DRAE3M**

3/5/8: 12.8 Inch (325 mm)  
21/36: 13.3 Inch (338 mm)

1.6 Inch (41 mm)

5.3 Inch (135 mm)

**HP** 1.2 H.P. (900 W)

**cfm** 35 cfm (16.5 L/s) Max

**Lbs** 3/5/8: 4.5 Lbs. (2.0 Kg): Short  
21/36: 4.7 Lbs (2.1 Kg): Short  
3/5/8: 5.1 Lbs. (2.3 Kg): Extended  
21/36: 5.3 Lbs (2.4 Kg): Extended

**SUPPLY** 3/8" NPT Inlet  
1/2" (13 mm) Hose Size

#### STANDARD EQUIPMENT

- Tool
- Operating Instructions and Service Manual

#### 300DRA(X)M, 300DRAE(X)M, 400DRA(X)M, 400DRAE(X)M Series Alternate Options

